

D
C
B
A

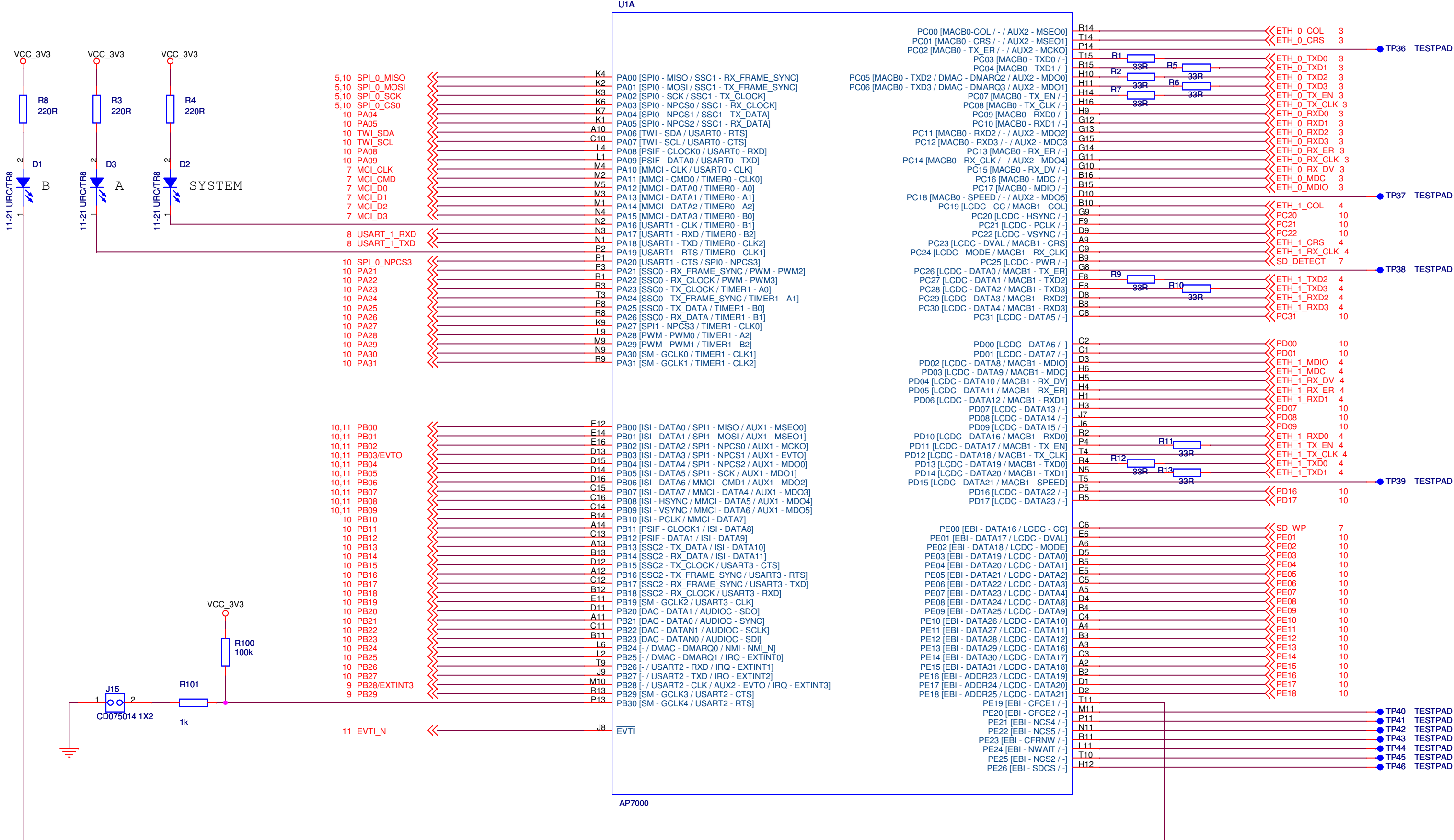

<Core Design>

ATMEL Norway AS
Vestre Rosten 79
N-7075 TILLER
Norway



Title	AP7000_1	Rev	PC1
Size	A3	Document Number	<Doc>
Date:	Tuesday, November 07, 2006	Sheet	1 of 13

AP7000_2

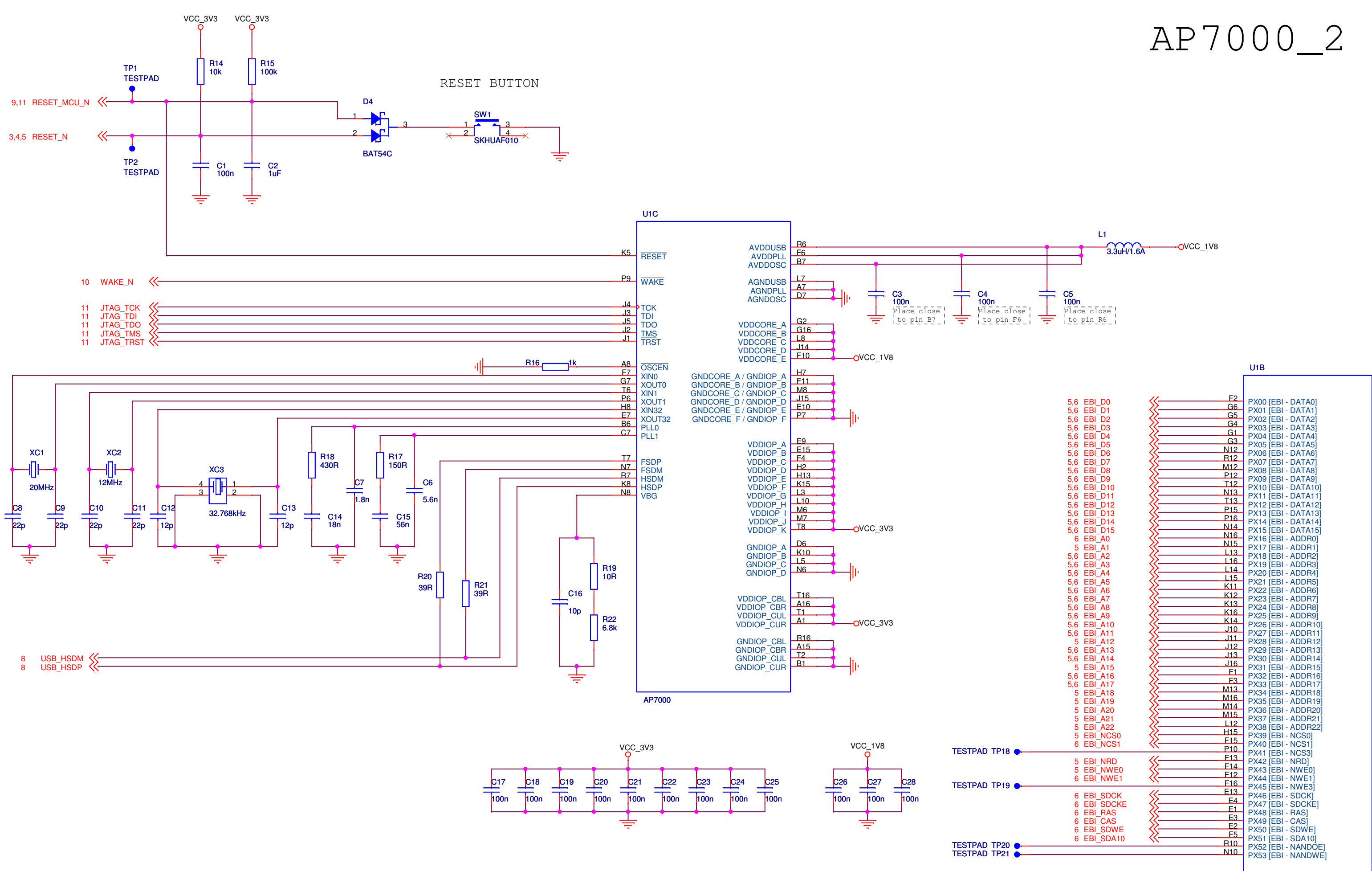

ETHERNET PORT 0

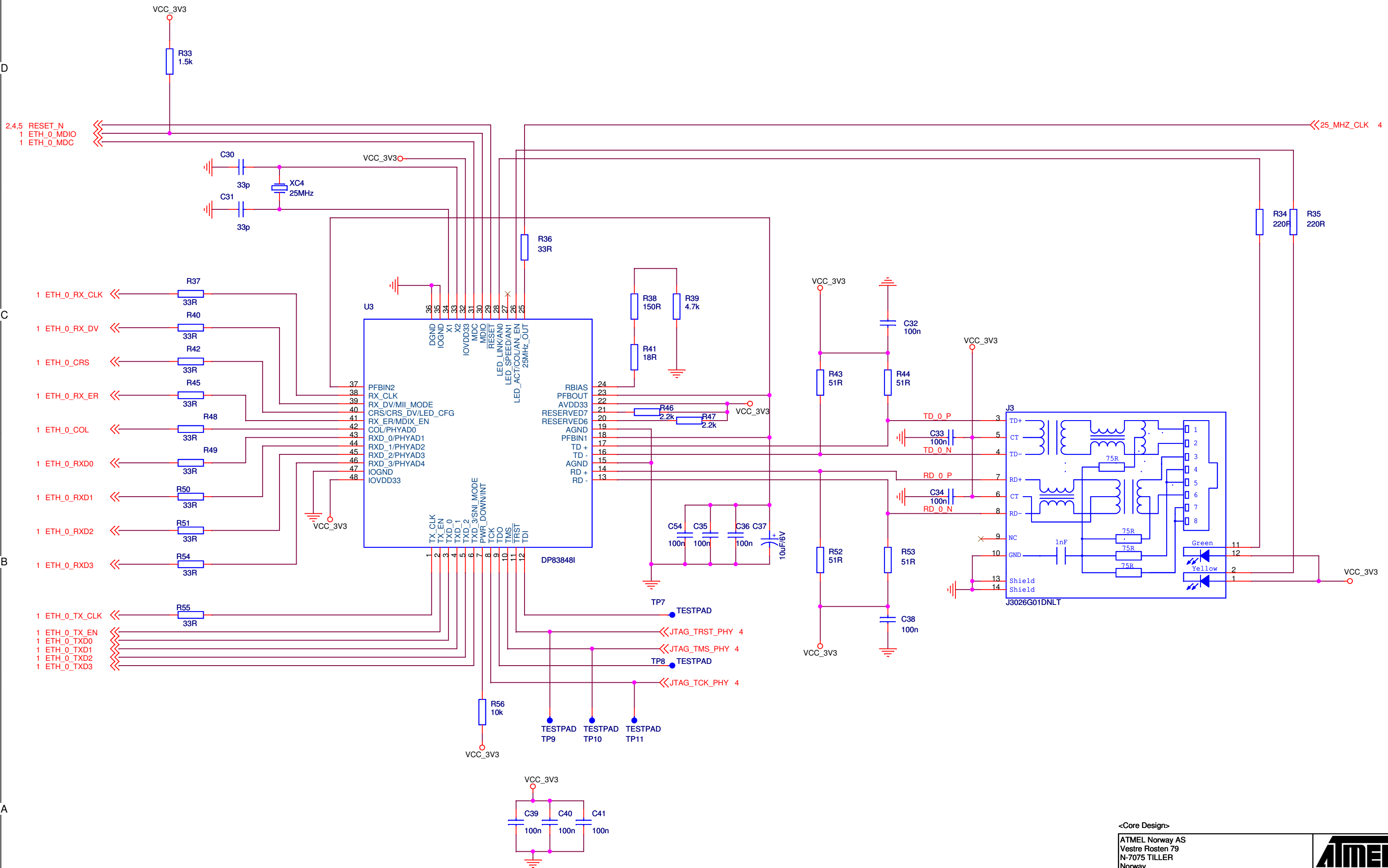

<Core Design>

ATMEL Norway AS
Vestre Rosten 79
N-7075 TILLER
Norway



Title	Ethernet port 0	
Size	Document Number	Rev
A3	<Doc>	PC1
Date:	Tuesday, November 07, 2006	Sheet 3 of 13

ETHERNET PORT 1

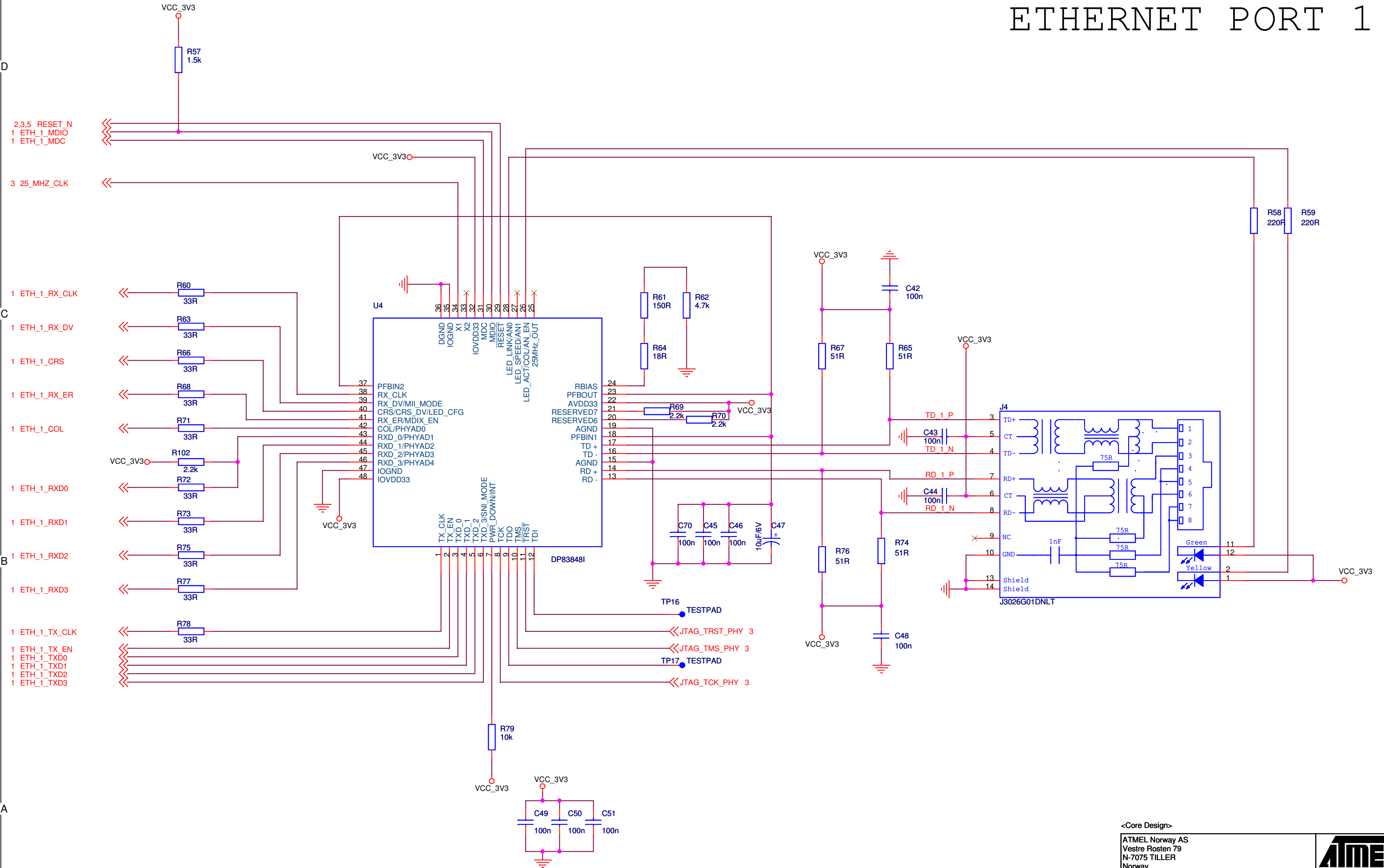

<Core Design>	
ATMEL Norway AS Vestre Rosten 79 N-7075 TILLER Norway	
Title	Ethernet port 1
Size	Document Number
A3	<Doc>
Date:	Tuesday, November 07, 2006
Sheet	4 of 13
Rev	PC1

NOTE: The serial FLASH are possible to update with larger memories in the future within the same footprint.

8MB parallel FLASH

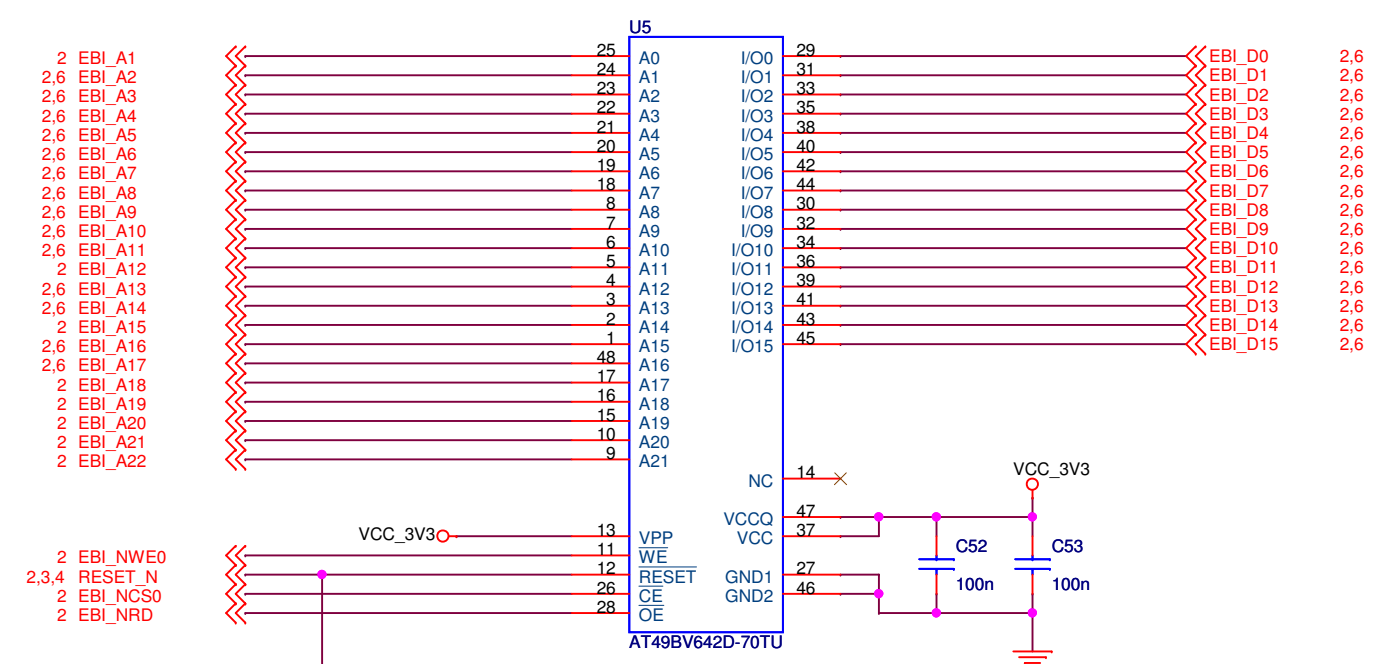

8MB serial FLASH

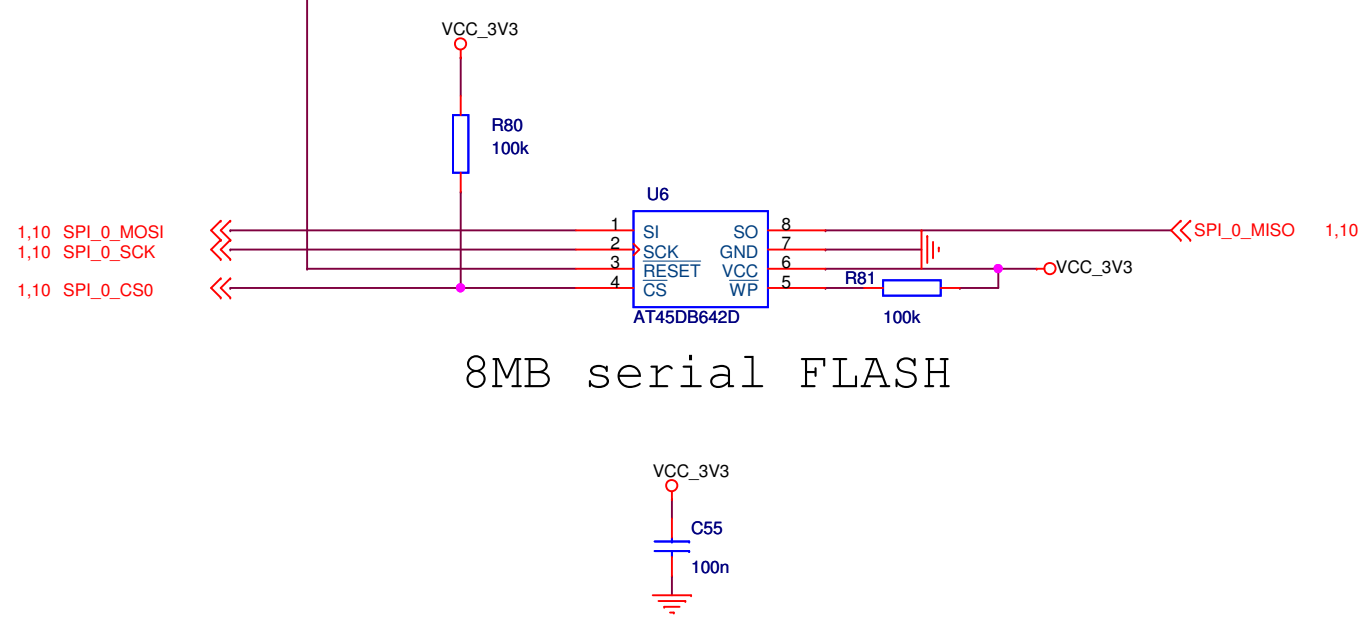

<Core Design>

ATMEL Norway AS
Vestre Rosten 79
N-7075 TILLER
Norway



Title	FLASH	
Size	Document Number	Rev
A3	<Doc>	PC1
Date:	Tuesday, November 07, 2006	Sheet 5 of 13

NOTE: The SDRAM are possible to update with larger memories in the future within the same footprint.

32MB

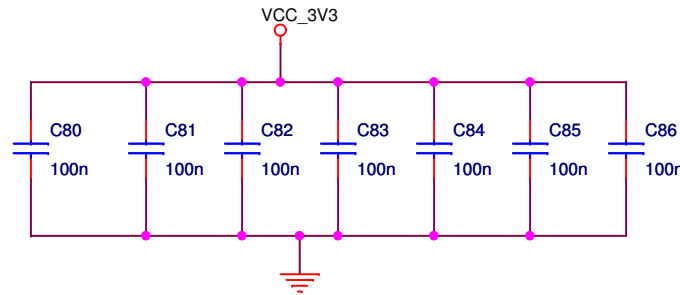
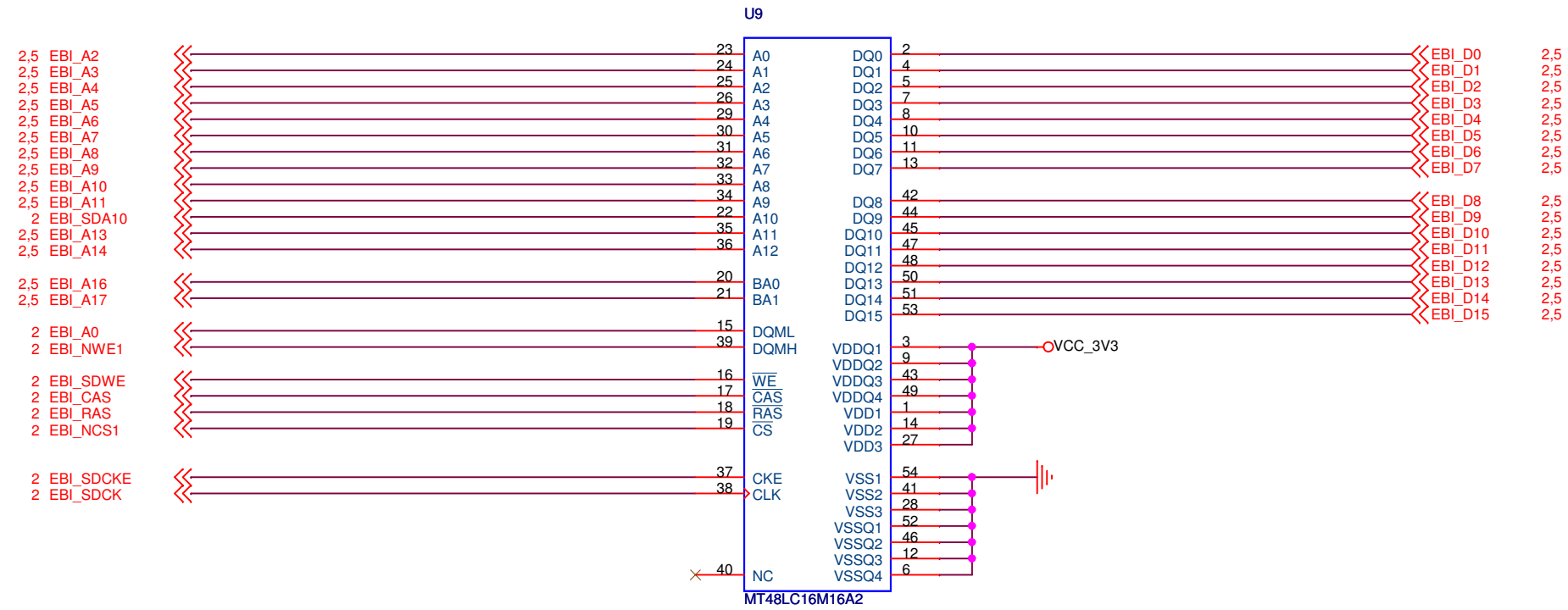

<Core Design>

ATMEL Norway AS
Vestre Rosten 79
N-7075 TILLER
Norway



Title SDRAM

Size A3 Document Number <Doc>

Rev PC1

Date: Tuesday, November 07, 2006 | Sheet 6 of 13

SD/MMC

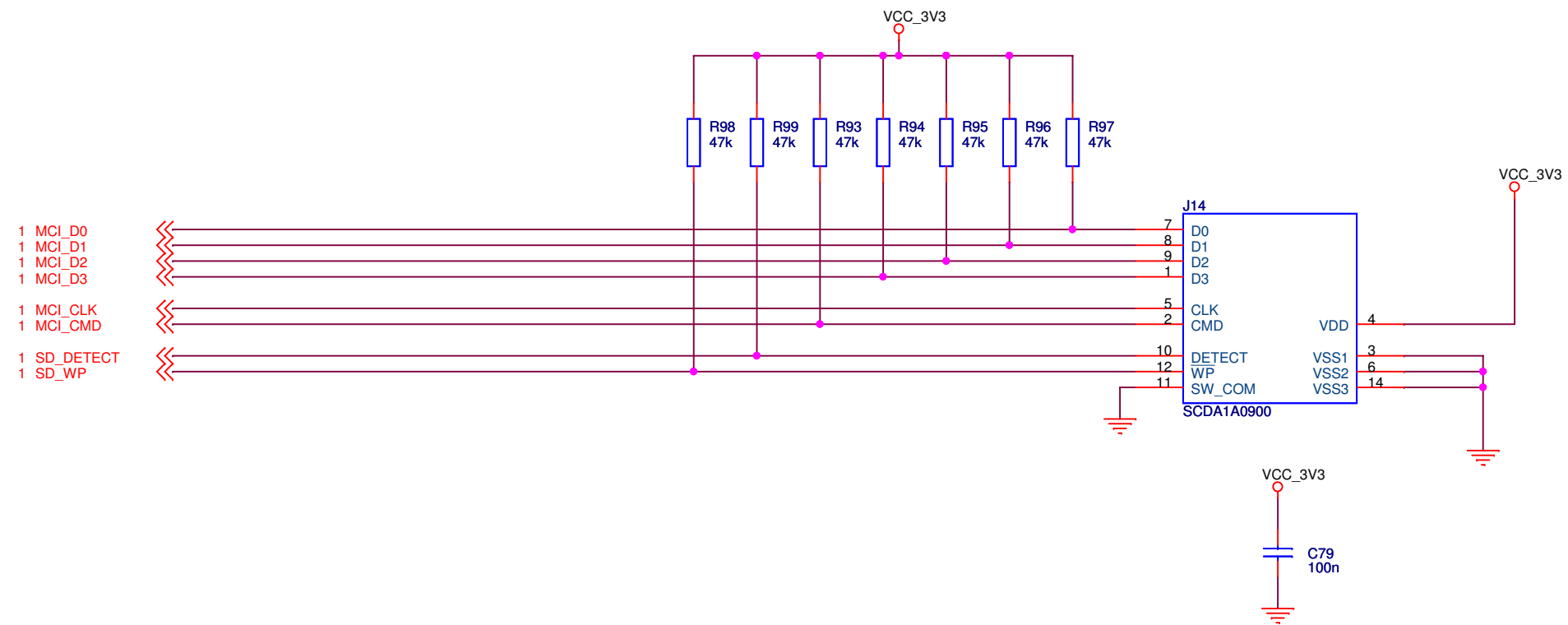

<Core Design>

ATMEL Norway AS
 Vestre Rosten 79
 N-7075 TILLER
 Norway



Title SD/MMC

Size A3
 Document Number <Doc>

Rev PC1

Date: Tuesday, November 07, 2006 | Sheet 7 of 13

RS-232 / USB

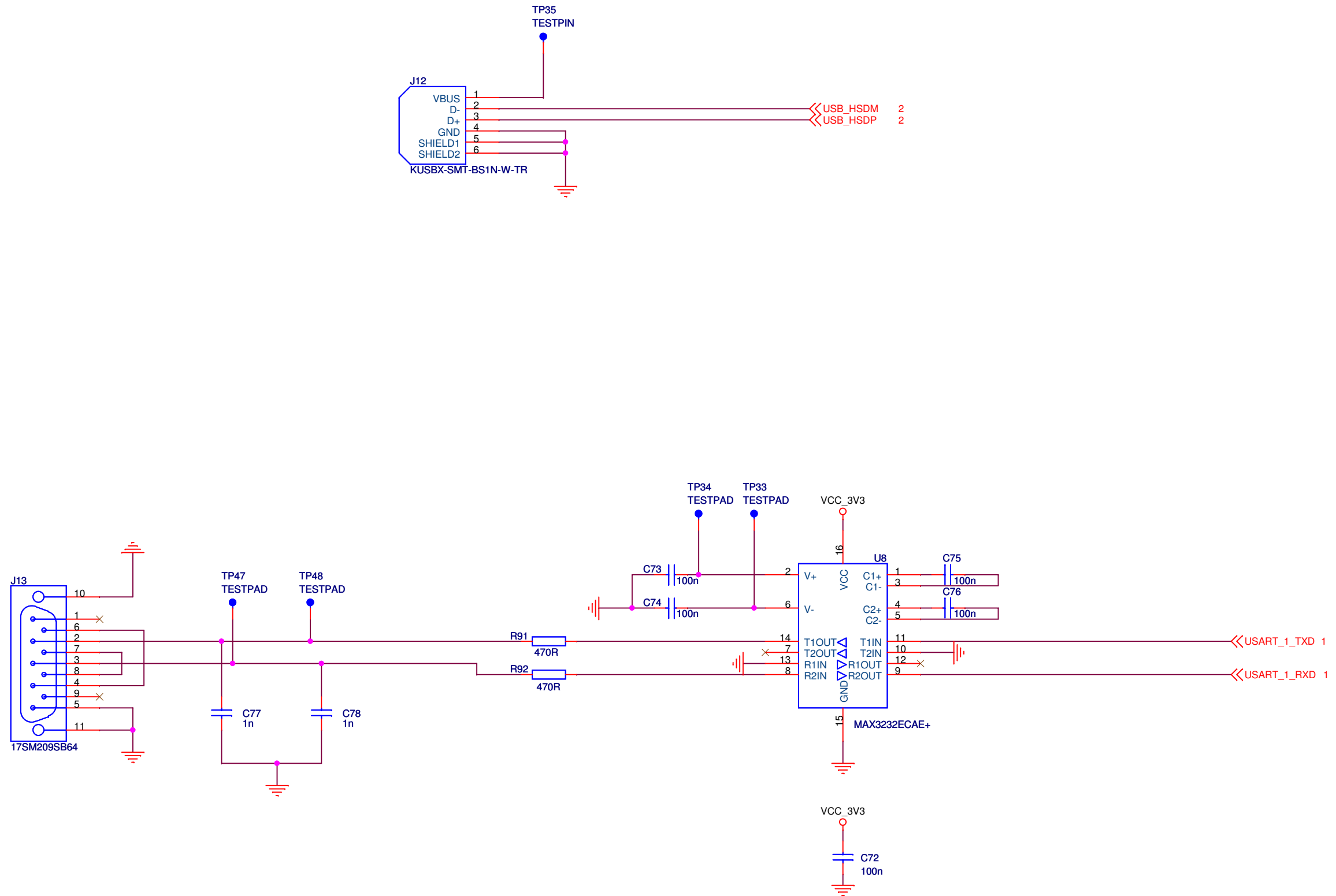

<Core Design>

ATMEL Norway AS
Vestre Rosten 79
N-7075 TILLER
Norway



Title RS-232/USB

Size A3
Document Number <Doc>

Rev PC1

Date: Tuesday, November 07, 2006 | Sheet 8 of 13

BOARD CONTROL

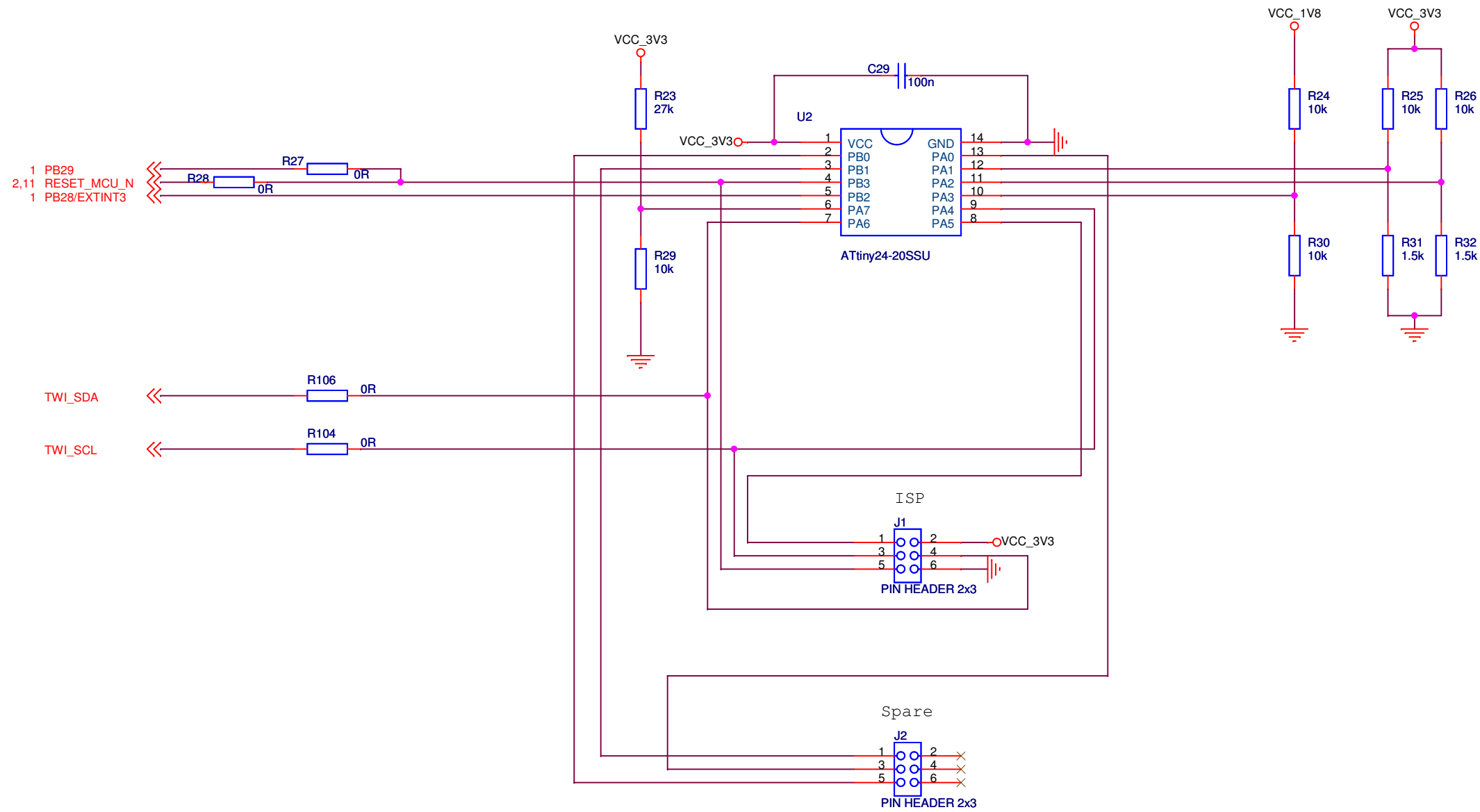

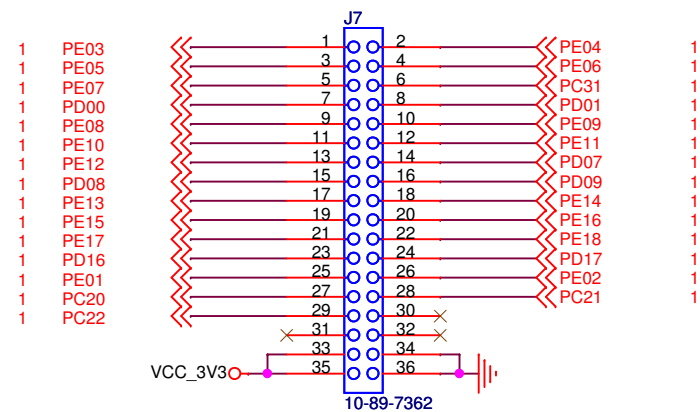
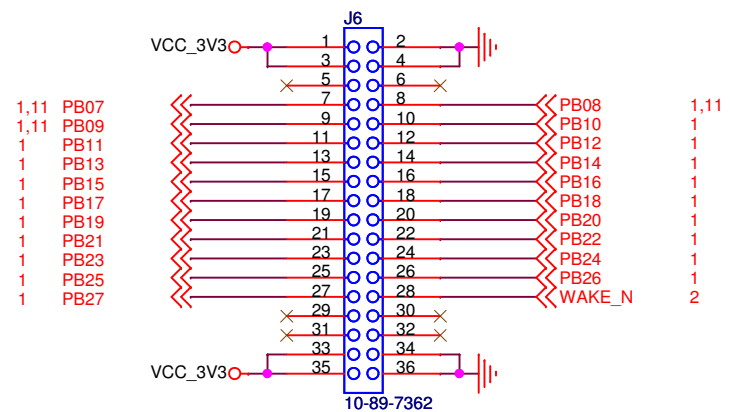
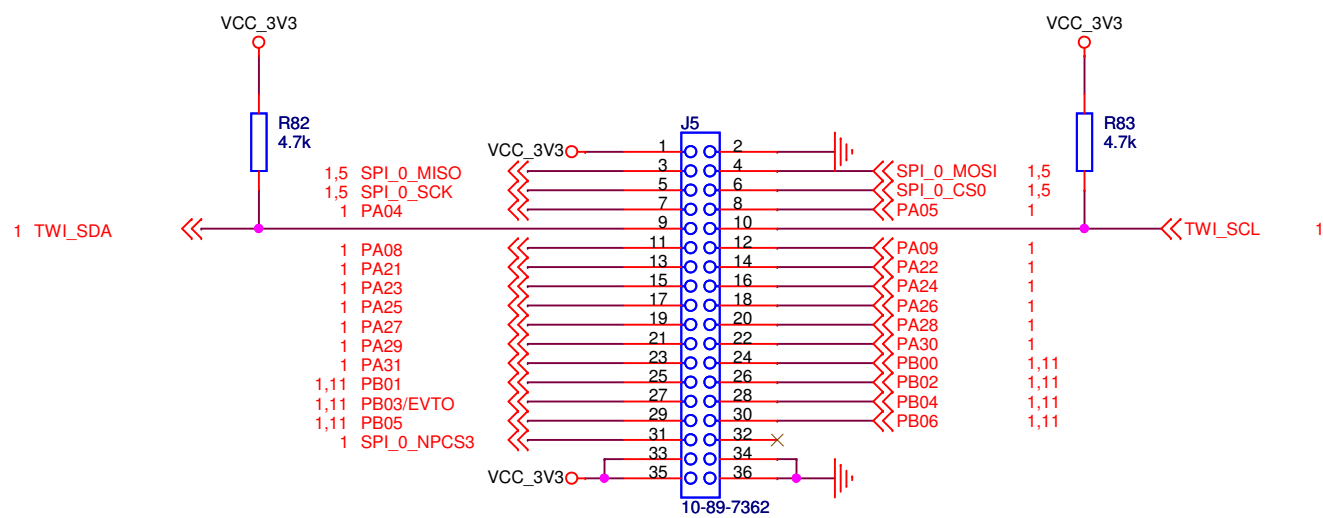

<Core Design>

ATMEL Norway AS
Vestre Rosten 79
N-7075 TILLER
Norway



Title GPIO

Size A3
Document Number <Doc>

Rev PC1

Date: Tuesday, November 07, 2006 | Sheet 10 of 13

JTAG_NEXUS

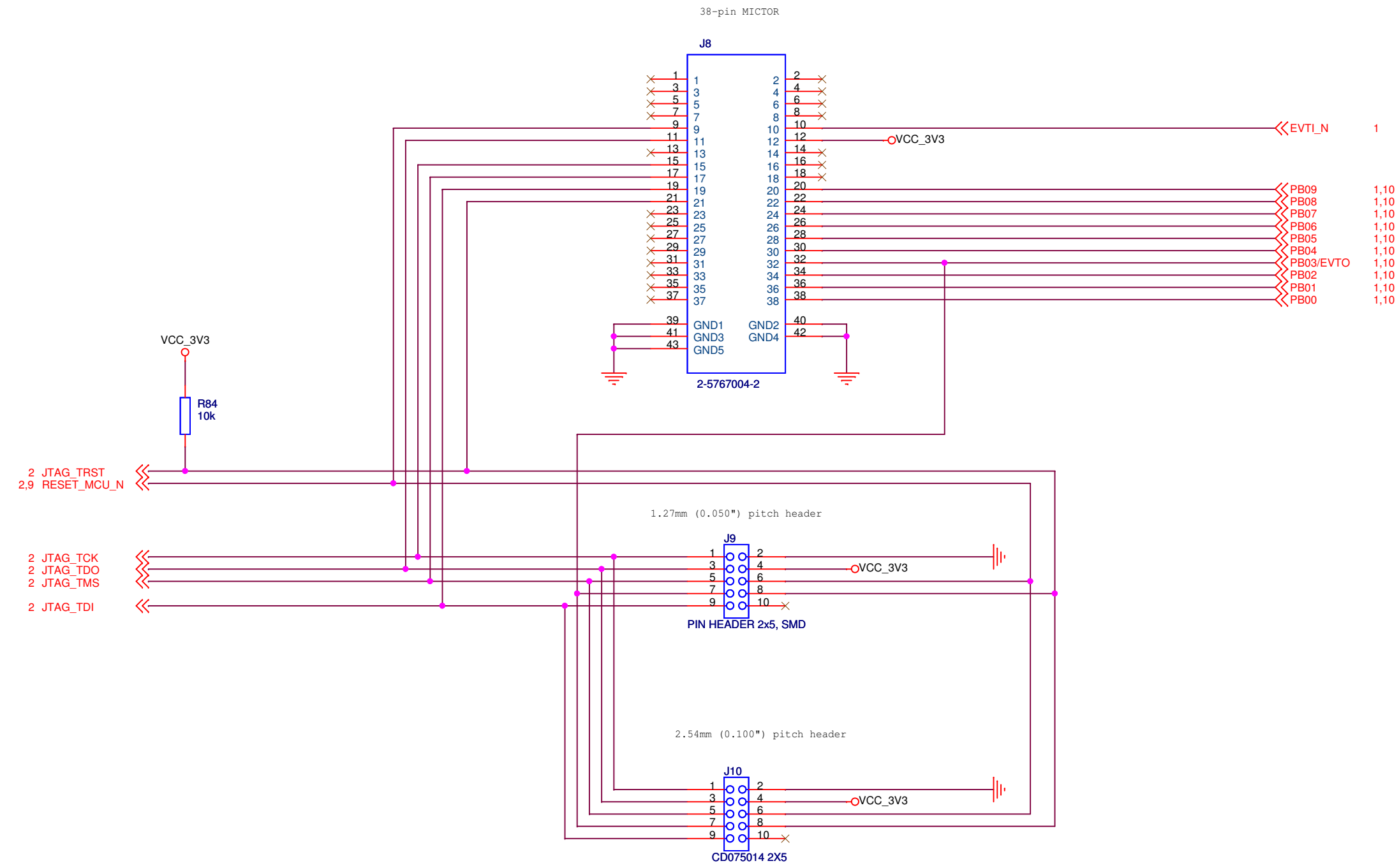

<Core Design>

ATMEL Norway AS
 Vestre Rosten 79
 N-7075 TILLER
 Norway



Title JTAG/NEXUS

Size A3 Document Number <Doc> Rev PC1

Date: Tuesday, November 07, 2006 Sheet 11 of 13

Input voltage 9-15V

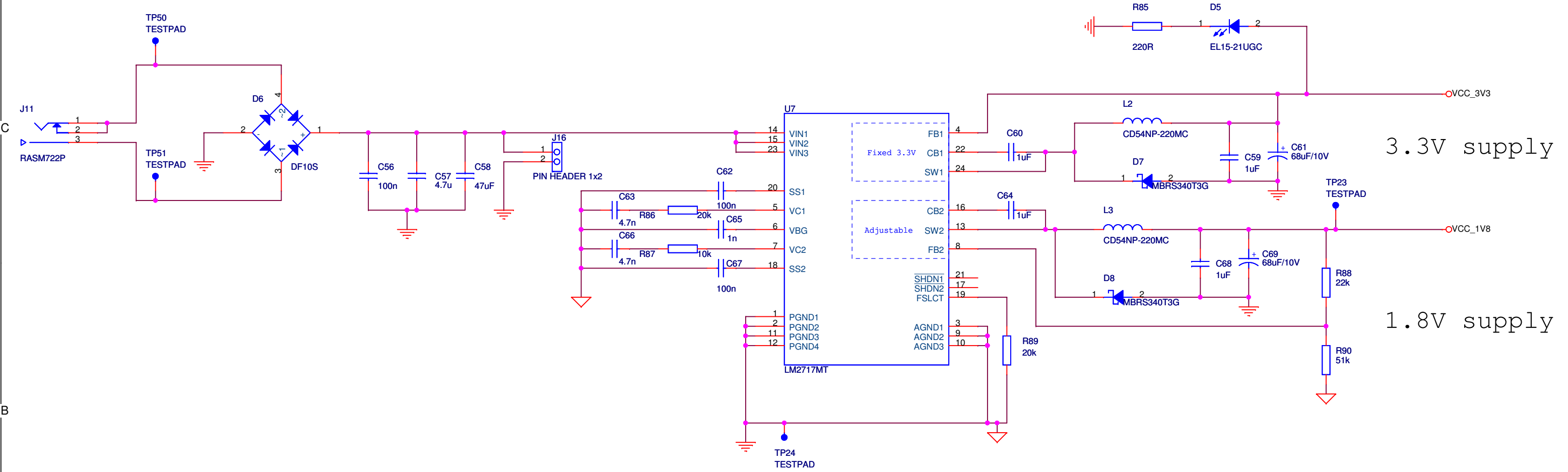

3.3V supply

1.8V supply

<Core Design>

ATMEL Norway AS
Vestre Rosten 79
N-7075 TILLER
Norway



Title		Power
Size	Document Number	Rev
A3	<Doc>	PC1
Date:	Tuesday, November 07, 2006	Sheet 12 of 13

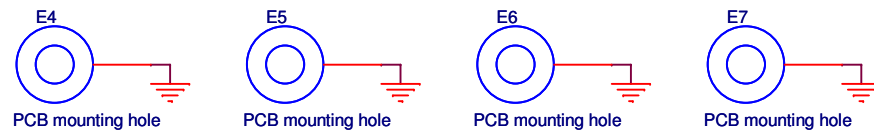
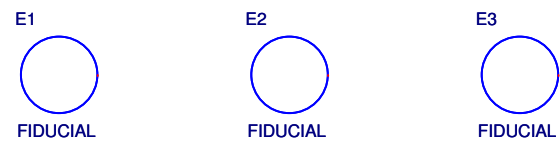
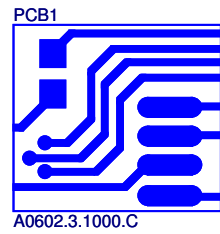

<Core Design>

ATMEL Norway AS
Vestre Rosten 79
N-7075 TILLER
Norway



Title Non Electrical

Size A3 Document Number <Doc>

Rev PC1

Date: Tuesday, November 07, 2006 Sheet 13 of 13